

0.11 MAX

3.25 +/- 0.01

3.25 (3.26) +/- 0.01

DOTTED LINES AND PARENTHEZIZED FIGURES ARE APPLICABLE TO BEZEL LIGHTED UNITS ONLY. (REFER TO BEZEL CONFIGURATION ON PAGE 2).

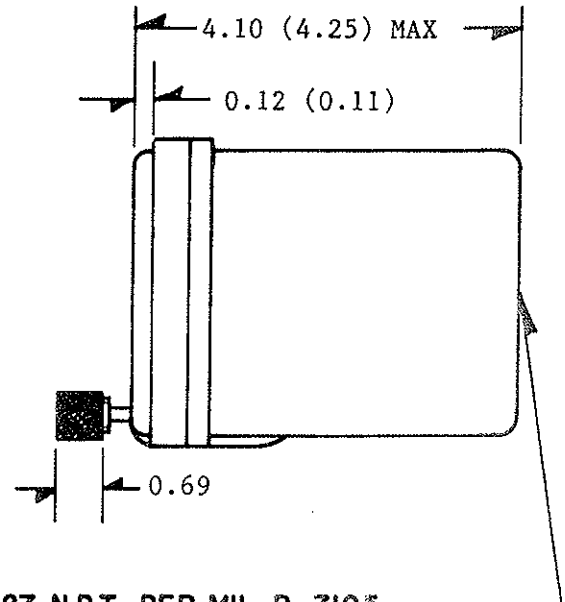
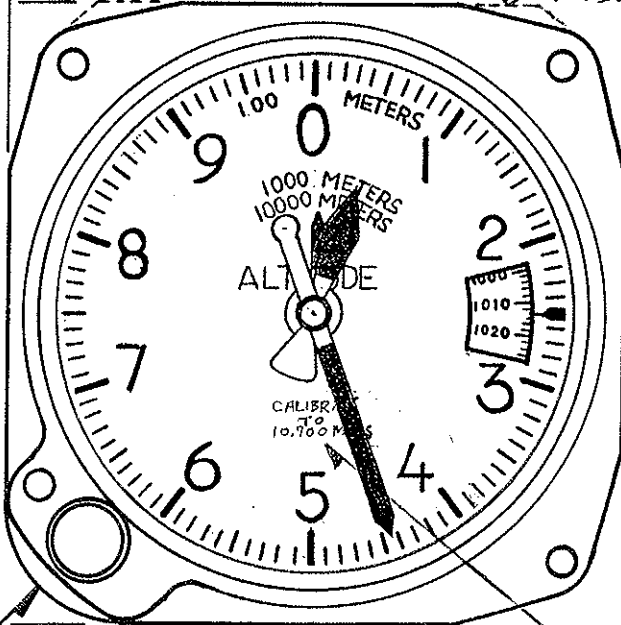

1/8-27 N.P.T. PER MIL-P-7105

POINTER CONFIGURATION "A" WITH Mb BAROMETRIC SCALE DIAL

CASE PER MS33549, EXCEPT AS SHOWN

CALIBRATED RANGE MARKING:
"CALIBRATED TO 6,100 METERS" OR
"CALIBRATED TO 10,700 METERS"

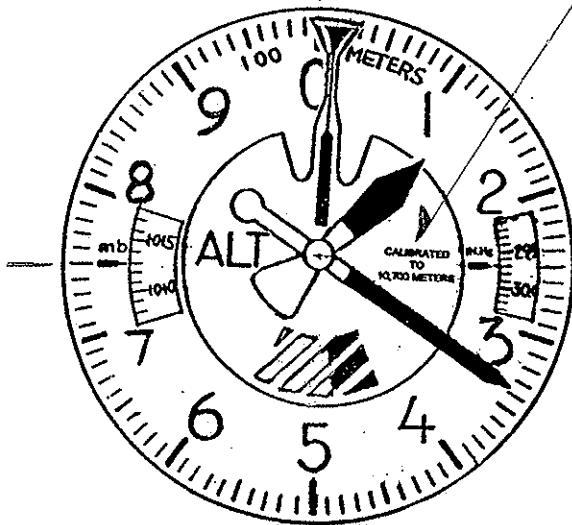

POINTER CONFIGURATION "C" FOR DUAL BAROMETRIC SCALE (Mb AND IN.Hg) DIAL (BARBER POLE ON 10K FT POINTER)

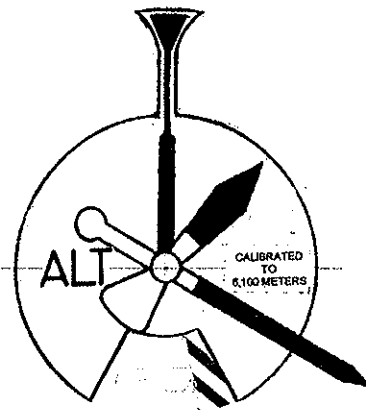

POINTER CONFIGURATION "B" FOR SINGLE BAROMETRIC SCALE (Mb OR IN.Hg) DIAL (BARBER POLE MARKING ON DIAL)

REV.	DATE	CHK.	REV.	DATE	CHK.	NAME	DATE
D	4/14/65		E	10/21/65		TR	8/30/61
						T. Dawson	4/14/65
							4/14/65

UNITED INSTRUMENTS, INC.



3625 COMOTARA AVE.
WICHITA, KS 67226

TITLE:

INDICATOR-ALTIMETER
(METRIC)

SPEC. NO:

UI5934-M

ISSUE

E

PAGE 1 OF 5 PAGES

UNITED INSTRUMENTS, INC. PART NO.	CODE NO.	POINTER CONFIG	RANGE in Meters	BARO SCALE	BEZEL CONFIGURATION
5934-3M	A.626	A	-300 to 6,100	Mb	Unlighted
5934-3M	A.626P	A	-300 to 6,100	Mb	Bezel Lighted, Plastic Wedge
5934-3M	A.626H	A	-300 to 6,100	Mb	Bezel Lighted, Glass Wedge, HEA
5934D-3M	A.627	A	-300 to 6,100	Mb and In.Hg	Unlighted
5934D-3M	A.627P	A	-300 to 6,100	Mb and In.Hg	Bezel Lighted, Plastic Wedge
5934D-3M	A.627H	A	-300 to 6,100	Mb and In.Hg	Bezel Lighted, Glass Wedge, HEA
5934A-3M	A.628	A	-300 to 10,700	Mb	Unlighted
5934A-3M	A.628P	A	-300 to 10,700	Mb	Bezel Lighted, Plastic Wedge
5934A-3M	A.628H	A	-300 to 10,700	Mb	Bezel Lighted, Glass Wedge, HEA
5934DA-3M	A.629	A	-300 to 10,700	Mb and In.Hg	Unlighted
5934DA-3M	A.629P	A	-300 to 10,700	Mb and In.Hg	Bezel Lighted, Plastic Wedge
5934DA-3M	A.629H	A	-300 to 10,700	Mb and In.Hg	Bezel Lighted, Glass Wedge, HEA
5934P-3M	A.664	B	-300 to 6,100	Mb	Unlighted
5934P-3M	A.664P	B	-300 to 6,100	Mb	Bezel Lighted, Plastic Wedge
5934P-3M	A.664H	B	-300 to 6,100	Mb	Bezel Lighted, Glass Wedge, HEA
5934PD-3M	A.665	C	-300 to 6,100	Mb and In.Hg	Unlighted
5934PD-3M	A.665P	C	-300 to 6,100	Mb and In.Hg	Bezel Lighted, Plastic Wedge
5934PD-3M	A.665H	C	-300 to 6,100	Mb and In.Hg	Bezel Lighted, Glass Wedge, HEA
5934PA-3M	A.666	B	-300 to 10,700	Mb	Unlighted
5934PA-3M	A.666P	B	-300 to 10,700	Mb	Bezel Lighted, Plastic Wedge
5934PA-3M	A.666H	B	-300 to 10,700	Mb	Bezel Lighted, Glass Wedge, HEA
5934PDA-3M	A.667	C	-300 to 10,700	Mb and In.Hg	Unlighted
5934PDA-3M	A.667P	C	-300 to 10,700	Mb and In.Hg	Bezel Lighted, Plastic Wedge
5934PDA-3M	A.667H	C	-300 to 10,700	Mb and In.Hg	Bezel Lighted, Glass Wedge, HEA

NOTES:

- Code number ending with "P" represents a unit equipped with lighting bezel (plastic wedge type): BA3-001-003A. These units require light tray P/N BA (VOLTAGE)-24T-BW3. The voltage requirement (5,14, or 28 volt) is to be specified by the customer after a UI code number ending with "P", otherwise the unit will be shipped without a light tray.
- Code number ending with "H" represents a unit equipped with lighting bezel (HEA glass wedge type): BA3-001-003G-901. These units require light tray P/N BA (VOLTAGE)-24T-BW3G. The voltage requirement (5,14, or 28 volt) is to be specified by the customer after a UI code number ending with "H", otherwise the unit will be shipped without a light tray.
- The light tray lead wire shall be per SAE AS22759/16-24. The white wire is for the rated lighting voltage and the black is for ground. E
- Optional LED Light Tray Assembly for both plastic and glass wedge type bezels (P/N BA (VOLTAGE) LED-24T). E

CUSTOMER
ACCEPTANCE
SPECIFICATION
UNITED INSTRUMENTS, INC.

TITLE:
INDICATOR – ALTIMETER
(METRIC)

SPEC. NO:
UI934-M

ISSUE

E

THESE INSTRUMENTS MEET OR EXCEED REQUIREMENTS OF UNITED INSTRUMENTS, INC. SPECIFICATION UI5934, SUBJECT TO THE FOLLOWING AMENDMENTS:

1. RANGE: The range of Model 5934-M Altimeter shall be -300 to 10,700 meters (-984 to 35,105 feet), maximum.
2. Dial and pointer configuration are approximately as shown.
3. Color of context is matte white on a dull black background. The colors shall be White: No. 37925 and Black: No. 37038 per FED-STD-595A.
4. INDIVIDUAL PERFORMANCE REQUIREMENTS:
 - 4.1. SCALE ERROR: With the barometric pressure scale at 1013.25 mb, the altimeter shall be subjected successively to pressures corresponding to the altitude specified in Table I up to the maximum calibrated range of the altimeter being tested. The reduction in pressure shall be made at a rate not in excess of 6,000 meters (19,685 ft) per minute to within approximately 600 meters (1,969 ft) of the test point. The test point shall be approached at a rate compatible with the test equipment. The altimeter shall be kept at the pressure corresponding to each test point for at least one minute, but not more than ten minutes, before reading is taken. The error at all test points must not exceed the tolerances specified in Table I. Following a minimum delay of four hours this test may be repeated and the altimeter shall meet tolerances as specified in Table I.
 - 4.2. HYSTERESIS: The hysteresis test shall begin not more than 15 minutes after the altimeter's initial exposure to the pressure corresponding to the upper limit of the scale error test. While the altimeter is at this pressure, the hysteresis test shall commence. Pressure shall be increased at a rate simulating a descent in altitude at the rate of 1,500 to 6,000 meters (4,921 to 19,685 ft) per minute until within 900 meters (2,953 ft) of the first test point (50 percent of maximum altitude). The test point shall then be approached at a rate of approximately 1,000 meters (3,281 ft) per minute. Within 10 seconds after the pressure has been stabilized at the test point, the instrument indication shall be within 30 meters (100 ft.) of the scale error reading obtained in Scale Error test. The altimeter shall be kept at this pressure for at least 5 minutes, but not more than 15 minutes, before the reading is taken. After the reading has been taken, the pressure shall be increased further, in the same manner as before, until the pressure corresponding to the second test point (40 percent of maximum altitude) is reached. The altimeter shall be kept at this pressure for at least one minute, but not more than 10 minutes, before the test reading is taken. After the reading has been taken, the pressure shall be increased further, in the same manner as before, until atmospheric pressure is reached. The reading of the altimeter at either of the two test points shall not differ by more than 22 meters (72 ft) from the reading of the altimeter for the corresponding altitude recorded during the scale error test.
 - 4.3. AFTER EFFECT: Not more than five minutes after the completion of the hysteresis test, the reading of the altimeter (corrected for any change in atmospheric pressure) shall not differ from the original reading by more than 9 meters (30 ft).
 - 4.4. FRICTION: The altimeter shall be subjected to a steady rate of decrease of pressure of approximately 230 meters (755 ft) per minute. At each altitude listed in Table II, the altimeter reading will be noted before and after vibration. The difference shall not exceed tolerances shown in Table II.
 - 4.5. CASE LEAK: The leakage of the altimeter case, when the pressure within it corresponds to an altitude of 5,500 meters (18,045 ft), shall not change the altimeter reading by more than 30 meters (98 ft) during an interval of 1 minute.
 - 4.6. POSITION ERROR: With atmospheric pressure applied to the instrument, the difference between pointer indication when the instrument is in normal operating position and when it is in any other position shall not exceed 6 meters (20 ft).

**CUSTOMER
ACCEPTANCE
SPECIFICATION
UNITED INSTRUMENTS, INC.**

TITLE:

INDICATOR - ALTIMETER
(METRIC)

SPEC. NO:

UI5934-M

PAGE 3 OF 5 PAGES

ISSUE

E

- 4.7. **BAROMETRIC SCALE ERROR:** At constant atmospheric pressure, the barometric pressure scale shall be set at each of the pressures (falling within its range of adjustment) listed in Table III and shall cause the pointer to indicate the equivalent altitude difference shown in Table III with a tolerance of 7 meters (23 ft). When the barometric pressure is set at 1013.25 mb, the reading in the In.Hg window shall be 29.920 +/- .005, as viewed approximately 12 inches away from the dial.
- 4.8. **POINTER OSCILLATION:** There shall be no more than 6 meters (20 ft) pointer oscillation when the instrument is subjected to vibration when mounted in normal operating position at frequencies to be varied uniformly from (a) 5 to 120 cycles per second at a maximum double amplitude of .036 inch (.91 mm) and a maximum acceleration of 1.5 g's; and (b) 120 to 500 cycles per second at a maximum acceleration of 0.5 g's.
5. **ENVIRONMENTAL CONDITIONS:** When installed in accordance with United Instruments, Inc. instructions, the altimeter will function in the following environmental ranges.
- 5.1. **TEMPERATURE:** -30°C to +50°C
- 5.2. **VIBRATION:**
- | Frequency | Max. Double Amplitude | Max. Acceleration |
|---------------|-----------------------|-------------------|
| 5 to 120 Hz | 0.036 Inch (.91 mm) | 1.5 g |
| 120 to 500 Hz | | 0.5g |
- 5.3. **HUMIDITY:** 0% to 95% at 32°C.
6. **CALIBRATION DATA:** Calibration Data shall be attached to each instrument.

TABLE I

SCALE ERROR

ALTITUDE Meters (Ft)	EQUIVALENT PRESSURE		TOLERANCE ± Meters (Ft)
	In.Hg	Mb	
-300 (-984)	31.001	1049.82	6 (20)
0 (0)	29.921	1013.25	6 (20)
150 (492)	29.393	995.37	6 (20)
300 (984)	28.872	977.73	6 (20)
450 (1,476)	28.359	960.35	7 (23)
600 (1,969)	27.853	943.22	9 (30)
900 (2,953)	26.864	909.73	9 (30)
1,200 (3,937)	25.903	877.18	10 (33)
1,800 (5,906)	24.064	814.91	12 (39)
2,400 (7,874)	22.332	756.25	18 (59)
3,000 (9,843)	20.703	701.09	24 (79)
3,700 (12,139)	18.925	640.88	27 (89)
4,300 (14,108)	17.502	592.69	30 (98)
4,900 (16,076)	16.166	547.45	33 (108)
5,500 (18,045)	14.915	505.08	36 (118)
*6,100 (20,013)	13.743	465.40	39 (128)
6,700 (21,982)	12.646	428.25	42 (138)
7,600 (24,934)	11.135	377.08	47 (154)
9,100 (29,856)	8.944	302.88	54 (177)
10,700 (35,105)	7.006	237.25	62 (203)

* Designates the last test point for the 6,100 meter (20,013 ft) range altimeters

**CUSTOMER
ACCEPTANCE
SPECIFICATION
UNITED INSTRUMENTS, INC.**

**TITLE:
INDICATOR - ALTIMETER
(METRIC)**

**SPEC. NO:
UI5934-M**

PAGE 4 OF 5 PAGES

ISSUE

E

TABLE II

FRICTION

<u>ALTITUDE</u> <u>Meters (Ft)</u>	<u>TOLERANCE</u> <u>± Meters (Ft)</u>
300 (984)	21 (69)
600 (1,969)	21 (69)
900 (2,953)	21 (69)
1,500 (4,921)	21 (69)
3,000 (9,843)	24 (79)
4,600 (15,092)	27 (89)
*6,100 (20,013)	30 (98)
7,600 (24,934)	36 (118)
9,100 (29,856)	42 (138)
10,700 (35,105)	48 (157)

* Designates the last test point for the 6,100 meter (20,013 Ft) range altimeters

TABLE III

PRESSURE/ALTITUDE DIFFERENCE

<u>PRESSURE</u> <u>Mb</u>	<u>ALTITUDE DIFFERENCE</u> <u>Meters (Ft)</u>	<u>PRESSURE</u> <u>In.Hg</u>	<u>ALTITUDE DIFFERENCE</u> <u>Meters (Ft)</u>
950	-538 (-1,766)	28.10	-526 (-1,727)
965	-408 (-1,337)	28.50	-408 (-1,340)
980	-278 (-913)	29.00	-263 (-863)
995	-151 (-495)	29.50	-119 (-392)
1,013	0 (0)	29.92	0 (0)
1,030	+141 (+461)	30.50	+162 (+531)
1,045	+263 (+863)	30.90	+272 (+893)
1,050	+304 (+996)	30.99	+297 (+974)
1,057	+360 (+1,181)		

18

CUSTOMER
ACCEPTANCE
SPECIFICATION
UNITED INSTRUMENTS, INC.

TITLE:
INDICATOR - ALTIMETER
(METRIC)

SPEC. NO:
UI5934-M

ISSUE

E

PAGE 5 OF 5 PAGES